

TCF

TULSI CHANRAI FOUNDATION

ANNUAL

REPORT

2025-2026

mission
FOR VISION

mission
FOR PRIMARY HEALTH

mission
FOR WATER



TCF
Tulsi Chanrai Foundation
partners in health

ANNUAL REPORT

Dear Patrons, Partners, Supporters and Friends,

As I reflect on the past year, I am filled with gratitude and pride for the extraordinary journey we have undertaken together. The 2025/26 year has been one of scale, equity, and sustainability — values that continue to guide our mission of transforming lives across Nigeria.

Through our Mission for Vision, nearly 20,000 surgeries restored sight and dignity, with the majority provided free of charge to those most in need. The launch of advanced retina services and the expansion of our hospital facilities in Abuja mark a bold step toward achieving a 30,000 annual surgical capacity — ensuring that no one is left behind in the fight against blindness.

Our Mission for Primary Health reached over 244,000 patients, with more than 80% receiving completely free care. From safe deliveries to immunization programs and malnutrition recovery, we are building healthier futures for mothers, infants, and children across the nation.

In our Mission for Water, we sustained 95% functionality of boreholes, rehabilitated boreholes, empowered communities and local mechanics to maintain water systems. This is more than infrastructure — it is about dignity, ownership, and resilience.

What makes these achievements remarkable is not just the numbers, but the lives behind them: the child who can now see her mother's face, the mother who delivers safely, the community that drinks clean water with pride. These are the stories of hope and transformation that define our work.

As we look ahead, our commitment remains unwavering: to scale our reach, deepen equity, and embed sustainability in every initiative. Together, with your continued support, we will build a future where health, vision, and clean water are not privileges, but rights enjoyed by all.

Thank you for walking this journey with us.

With gratitude and determination,

Shravan Kumar Kasam
Chief Executive Officer

TCF Annual Highlights 2025/26

Scale, Equity, and Sustainability: Transforming Lives Across Nigeria.

- 19,933 eye surgeries conducted - restoring sight and dignity
 - Abuja: 13,829 (62% free for disadvantaged patients)
 - Kebbi: 3,839
 - Calabar: 2,465
- 113,835 individuals treated, with most life-changing surgeries provided at no cost.
- Advanced Retina Specialty Services launched in Sept 2025, with 60 complex vitreoretinal surgeries performed.
- Hospital expansion underway: doubling free patient beds (60 → 120) and operating theatres (3 → 6), targeting 30,000 annual surgical capacity.

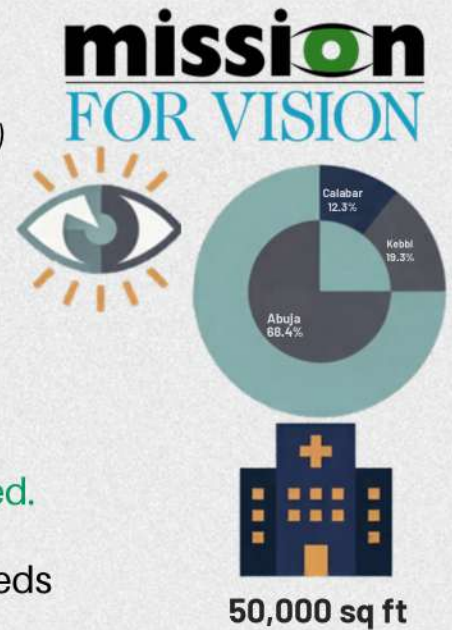

mission FOR PRIMARY HEALTH



- 244,179 patients treated across 30 facilities in Yoia, Zaria, and Edo.
- 81.6% (199,898 patients) received completely free care.
- 13,279 new ANC registrations, ensuring safer pregnancies and healthier infants.
- Immunization retention rate: 90.8% for the Pentavalent vaccine series, protecting infants against preventable diseases.
- 98% recovery rate for malnutrition: 2,607 of 2,659 children successfully rehabilitated.

- 95% functionality of hand pump boreholes (HPBHs)
- 500 HPBHs maintained through Village Level Operation & Maintenance.
- 40 boreholes rehabilitated, empowering 40 communities (34 Kebbi, 6 Kano) with ownership and sustainability culture.
- Capacity building: 900+ WASHCOM members trained (40% women), plus 60 village leaders equipped with sanitation and sustainability knowledge.
- Economic empowerment: Local Area Mechanics trained, equipped, and supported to repair 185 boreholes, creating livelihoods and resilience.

mission FOR WATER





mission FOR VISION

The Tuls Chanrai Foundation expanded affordable eye care through its Mission for Vision platforms in Abuja, Calabar, and Kebbi during the 2025-2026 cycle, achieving significant milestones. Key developments included the launch of retina specialty services in Abuja, high-volume free surgeries in Calabar, and house-to-house screenings in Kebbi. The Foundation successfully restored sight, reduced avoidable blindness, and enhanced community trust, enabling beneficiaries to resume various life roles. Future efforts will focus on maintaining surgical quality, expanding rural outreach, and improving resources and data validation.

These initiatives not only restored sight and reduced avoidable blindness but also renewed dignity, independence, and livelihoods—building trust and enabling beneficiaries to reclaim meaningful roles in society. Looking ahead, the Foundation is committed to sustaining surgical excellence, extending rural outreach, and enhancing resources and data validation to ensure quality, transparency, and long-term impact.



"We are not just delivering surgeries at scale. We are building systems that make quality eye care permanently accessible, highly specialized, and deeply responsive to community needs."

"Delivering both scale and equity, every region contributes in a distinct way to reducing avoidable blindness across Nigeria."



TCF Abuja EH: The Tertiary & Specialty Hub

The Tulsi Chanrai Foundation Eye Hospital commenced operations on January 15, 2019, and by January 2026, had provided eye care to approximately 501,319 outpatients and performed 60,531 surgeries for both free and paying patients. Between April 2025 and March 2026, the hospital treated 113,835 patients, of whom 10,972 were referred for specialized diagnostic procedures and 14,471 received optical aids. During this period, a total of 13,629 surgeries were conducted, with nearly 62% offered free of charge to economically and socially disadvantaged individuals — reaffirming the hospital's commitment to accessible and inclusive eye care.

TCF EYE HOSPITAL Performance Overview: January 2019 - January 2026



Equity Focus: Total Surgeries



Clinical Milestones & Expansion



Retina Specialty Launch

Advanced vitreoretinal services were launched in September 2025, reaching 337 OPD patients and performing 60 complex surgeries during the first specialist visit.



Global Accreditation

The hospital achieved dual recognition in September 2025, with inspection by the West African College of Ophthalmology and official center accreditation by the Ophthalmology Foundation—USA.



Hospital Expansion

The hospital's expansion work to double free patient beds (60 to 120), double operating theatres (3 to 6), and increase annual surgical capacity to 30,000 is ongoing as per schedule.



Keffi Vision Centre

Established our first Vision Center at Keffi to deliver primary eye care directly to patients in Nasarawa State, drastically reducing the travel burden for routine management.



Calabar: The Established Community Network

Since June 2003, TCF has partnered with the Cross River State Government to deliver free cataract surgeries and established a Community Ophthalmology Program in Calabar on March 22, 2004.

The combined efforts — government infrastructure and TCF expertise — has transformed access to care and restored sight through 52,517 surgeries to date.



Surgeries by Age Group | Calabar

Apr 2025 - Mar 2026



Total: 2,465 surgeries

To meet the rising demand for cataract services, TCF is expanding screening camps in partnership with V Care, FCMB, and Azura; strengthening rural transport links with General Hospital Ugep, Holy Family Ikom, and General Hospital Ogoja; and mitigating personnel shortages through structured mentoring and local staff training.



Outreach Camp

Kebbi: Overcoming Blindness

Mission for Vision - Kebbi remained a vital eye-care access point for underserved communities in north-western Nigeria during the reporting period. In partnership with the Kebbi State Government, the program combined free cataract surgeries with high-volume community outreach to reduce avoidable blindness. Service delivery was strong, with 10,167 outpatient consultations, 12,882 individuals screened, and 7,711 households covered through the Cataract Backlog Free LGA Project in Aliero. A total of 3,839 surgeries were conducted, with 89.7% of beneficiaries above 45 years, aligning with the age group most affected by cataract-related impairment.

Kebbi State accounted for 88% of surgical beneficiaries, while additional patients came from Sokoto, Zamfara, Niger, Kwara, and neighboring Niger and Benin Republic. This broad reach underscores the program's dual role as both a state-level service platform and a trusted regional referral hub, reinforcing its reputation as a cornerstone of accessible, quality eye care in northern Nigeria.



THE KEBBI EYE PROGRAM ELIMINATES SURGICAL CATARACT BACKLOG AT LGA LEVEL THROUGH HOUSE TO HOUSE SCREENING

The Cataract Backlog Free Aliero LGA Initiative

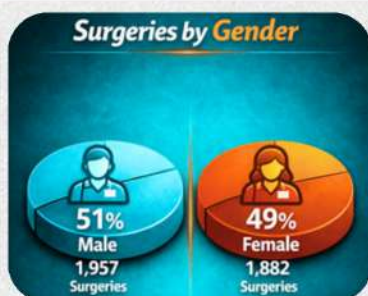
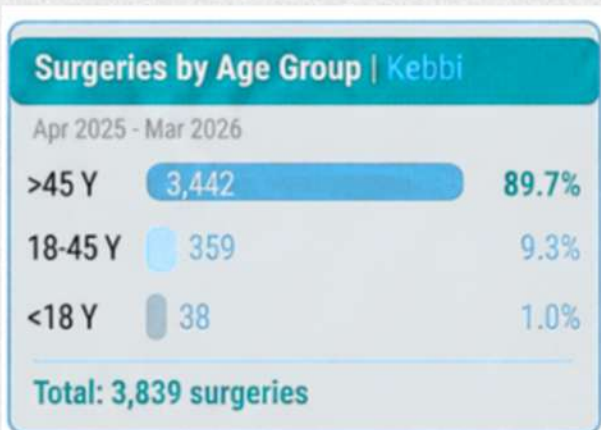

LIVELIHOOD RESTORED

Mr. Obinna David (Calabar)

After enduring three years of blindness, Mr. Obinna lost his livelihood as a farmer and restaurant owner, becoming entirely dependent on his elderly mother.

Following a successful cataract diagnosis and surgery in Calabar, he has regained full sight and is actively preparing to return to farming and reopen his business.



Before



After

“From dependency back to ownership.”

PUBLIC SERVICE & COMMUNITY SAFETY

Amos Ishaya, 55 Years Old (Kebbi)

Serving as a Deputy Superintendent of Police in Minna, Niger State, Amos developed a debilitating cataract in his right eye. Following surgery at the Hafsat Eye Centre in Kebbi, his 30-day review confirmed substantial visual improvement, enabling his immediate return to active duty.



Before



After

“Restoring sight supports community safety.”

EDUCATION & YOUTH

Christian, 10 Years Old (Calabar)

Christian faced severe vision problems from infancy, isolating him from school, church, and childhood activities.

Through the Mission for Vision program in Calabar, he received sight-restoring treatment, enabling him to pursue his education with clear vision.



Before



After

“From darkness to childhood dreams.”

“Every restored sight is more than a medical outcome; it is the return of dignity, independence, livelihood, and hope.”

mission

FOR PRIMARY HEALTH



Innovating and implementing scalable, replicable models for PHC service delivery across three distinct communities.



Reduce maternal, infant, and child mortality.



Immunize children against all vaccine-preventable diseases.



Reduce malnutrition among children.



Prevent transmission of HIV/AIDS from mother to child.



Innovate and implement scalable, replicable PHC models.

200,000 People Under Direct Coverage

The mission ensures healthcare security for 80,000 residents in Yola, 110,000 in Zaria, and 10,000 residents from host communities in Edo.



30 Health Facilities Establishing Local Access

The missions network is comprised of two specialized hospitals—GDCMH and GKMCH—along with one comprehensive health center located in EDO. Additionally, there are 27 health clinics and posts that serve as the primary points of contact for the community.



In the 2025/26 period, among the 244,179 patients who sought medical care, a significant 199,805 individuals (approximately 81.9%) received free services, while the remaining patients accessed subsidized care.

The TCFs Mission for Primary Health Care

Delivering Care at Scale

2025/26



- 244,179 Total Patients Treated
- 199,805 Patients Received FreeCare

82% of all TCF Primary Health Care services across the three regions are provided entirely free of charge, ensuring equitable access for vulnerable

Zaria
122,065 Treated
102,551 Free

Yola
105,931 Treated
91,480 Free

Edo
16,183 Treated
5,774 Free

Safeguarding Maternal Health



76.7% of all reported deliveries were conducted by skilled TCF project staff, directly addressing the core objective to reduce maternal and infant mortality through professional intervention.

Shielding Against Vaccine-Preventable Diseases

Total BCG Vaccinations: 8,868 infants |
Total Measles Vaccinations: 6,883 infants |

TCF demonstrates extraordinary patient retention. 90.8% of infants who receive Penta 1 successfully complete the full series through Penta 3, proving the immense efficacy of TCF's community tracking and follow-up models.

Yola is at the forefront of initial, early-stage BCG vaccinations with a total of 4,893, while Zaria holds the record for the highest number of later-stage Measles vaccinations at 3,839. This indicates distinct patterns of long-term engagement with the clinics.



Reversing Childhood Malnutrition



2,659 malnourished children identified 2,607 graduated





Zaria PHC



Yola PHC



Edo PHC

Mission for Primary Health Annual Summary 2025/26

SR. NO.	INDICATORS	EDO PHC	YOLA PHC	ZARIA PHC	TOTAL
1	Total Patients treated	16,183	105,931	122,065	244,179
2	Total Free patients	5,774	91,480	102,551	199,805
3	New ANC Registration	486	6,171	6,622	13,279
4	Skilled Deliveries- by Project Staff	188	3,785	4,551	8,524
5	Total Deliveries reported	305	6,164	4,638	11,107
6	Total Birthweights Recorded	307	4,172	4,635	9,114
7	No. of infants vaccinated-BCG	297	4,893	3,678	8,868
8	No. of infants vaccinated-Penta 1	286	4,260	3,671	8,217
9	No. of infants vaccinated-Penta 2	332	3,695	3,689	7,716
10	No. of infants vaccinated-Penta 3	326	3,510	3,629	7,465
11	No. of infants vaccinated-Measles	287	2,757	3,839	6,883
12	Pregnant women TT1 dose	291	5,066	5,371	10,728
13	Pregnant women TT2 dose	223	3,320	3,973	7,516
14	No. of malnourished children identified	8	1,239	1,412	2,659
15	No. of malnourished children graduated	4	1,003	1,600	2,607
16	Family planning services availed	244	3,422	4,623	8,289

“Strong primary health care is the foundation of healthy communities—bringing essential services closer to families, protecting mothers and children, and ensuring timely care before illness becomes severe.”

Lami's Legacy: From Maternal Crisis to Community Advocacy

The Clinical Emergency Critical Maternal Hemorrhaging.



Life-Saving Intervention



Ms Lami accompanied her daughter to a follow-up visit after her recovery.

The Ripple Effect of Advocacy Community Referrals.



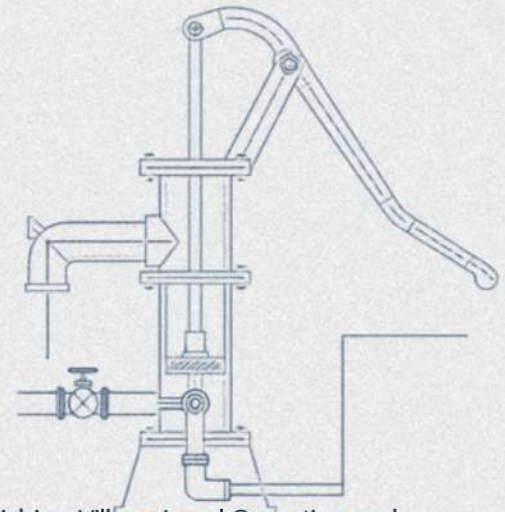

ESTABLISHING SUSTAINABLE WATER LIFELINES ACROSS NIGERIA

The Tuls Chanrai Foundation (TCF) - Mission for Water is dedicated to establishing Village Level Operation and Maintenance (VLOM) systems for drinking water facilities across Nigeria. This initiative focuses on forming WASHCOMs, providing practical training for local mechanics, building the capacity of pump caretakers on preventive maintenance and water source management, monitoring water quality, and linking communities with local supply chains for affordable, quality materials. Launched in 1996 in Kebbi State, Mission for Water began with the concept of "Rehabilitation with Human Values" for hand pumps, with Bagudo serving as the first Local Government Area (LGA) where TCF rehabilitated hand pump boreholes (HPBHs).

In the financial year 2025-26, the program is prioritizing the functionality and sustainable handover of hand pump boreholes to communities in Kebbi and Kano through the VLOM project. This approach includes rehabilitating non-functional boreholes, strengthening and reforming existing WASHCOMs, and fostering a culture of maintenance within communities. Recognizing that past efforts often rehabilitated boreholes without ensuring community ownership, TCF is now committed to building the capacity of community members and WASHCOMs to guarantee sustainability before handing over facilities. This strategy aims to promote better health outcomes while ensuring that over 95% of boreholes remain functional at any given time.

Mission for Water - 2025/26 Goals & Objectives:

- Maintain functionality: Ensure all 500 hand pump boreholes (HPBHs) deliver safe drinking water.
- Capacity building: Strengthen WASHCOM members in 60 targeted communities across Kebbi and Kano.
- Rehabilitation: Mobilize and rehabilitate 40 non-functional HPBHs in Kebbi and Kano states.
- Community ownership: Handover 40 strengthened WASHCOMs to local communities for sustainable management.
- Adoption: Identify and adopt 40 HPBHs (Kebbi: 34, Kano: 6) under the VLOM model.

Sustainable water requires community ownership, not just hardware installation.

The 2025-26 Evolution

TCF shifted focus to comprehensive capacity building before facility handover. The primary goal is now strengthening Water, Sanitation, and Hygiene Committees (WASHCOMs) to inculcate a permanent maintenance culture.



The Village Level Operation and Maintenance (VLOM) framework decentralizes care.

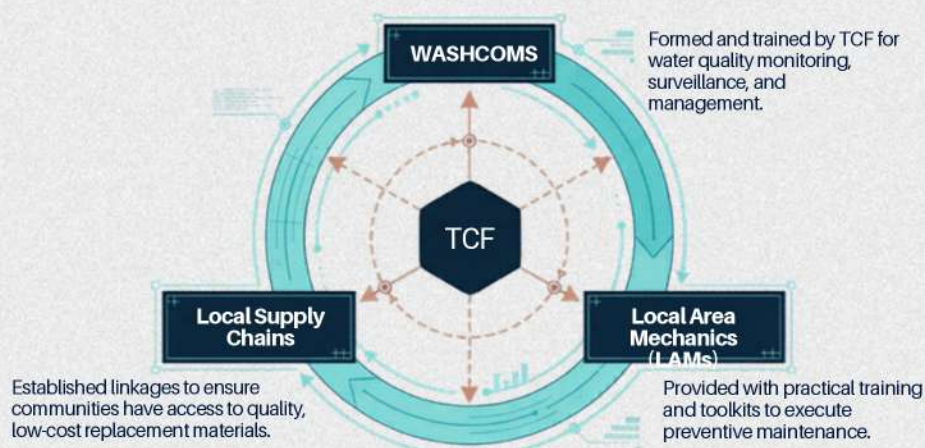

Rehabilitation and training secured water access across four regions.

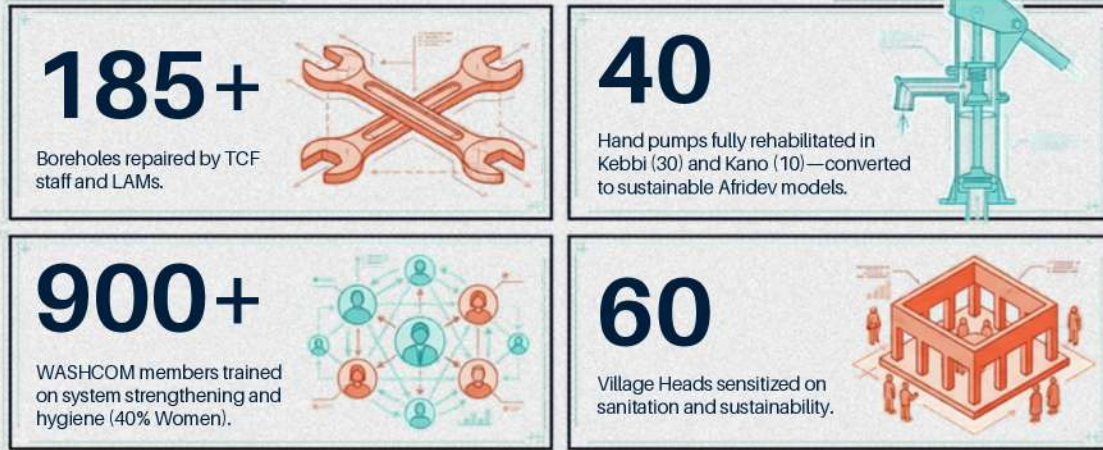

Continuous monitoring drove aggregate Hand Pump Borehole functionality to 95%.

500 Hand Pump Boreholes (HPBHs) Maintained			
Kebbi State	15 LGAs	250 HPBHs	99%
Kano State	2 LGAs	110 HPBHs	99%
FCT	2 LGAs	30 HPBHs	97%
Cross River State	3 LGAs	110 HPBHs	84%

Overall Performance
95%



Operational Insight: Real-time accountability is maintained through a weekly field monitoring system tracked via Google Spreadsheets, driving rapid response times.

Local Area Mechanics turn infrastructure maintenance into a sustainable economic engine.



"Sustainable water requires community ownership, not just hardware installation."

The proven VLOM model scales to Edo State through the Azura Power partnership.

Project Scope: The Safe Water Project. To ensure availability, accessibility, and affordability to potable water across 43 communities.

TCF- Azura Power Partnership



62% Failure Rate
 The Crisis: Out of roughly 90 Motorized Boreholes (MBHS) in the LGA, 56 are currently non-functional.

The Solution: Transitioning 43 broken MBGs into sustainable Solar Motorized Boreholes (SMBHS) using the exact community-owned VLOM framework perfected in Kebbi and Kano.

TCF: Leading Communities Toward Generational Health



The 2026-27 Horizon: Building on the 40 handed-over sites, TCF has already identified 40 new communities for adoption in the upcoming cycle.



Capacity Building to WASHCOM members



PRE



POST

HPBHs rehabilitation

**ACTIVITIES
 2025/26
 AT A GLANCE**



40 HPBHs Handed Over to respective WASHCOMs

The Tasara Community Transformation (Community Governance)

Step 1: Breaking Through Resistance

Initially, the Tasara community faced high rates of open defecation, and refused to contribute funds for repairs; TCF motivated the Village Head and facilitated exposure visits to successful nearby communities to spark change.



Step 2: Reforming the WASHCOM

TCF helped identify and re-form a Water Sanitation and Hygiene Committee (WASHCOM) and developed a Community Action Plan that was displayed at the mosque for public accountability.



Step 3: Establishing Financial Ownership

The community implemented a water tariff of 200 Naira per household monthly, managed through four different transparent registers to ensure trust and accountability.



Step 4: Achieving Self-Sufficient Hygiene

Today, Tasara has over 150,000 Naira in its WASH fund, pays a monitor 3,000 Naira monthly for 24/7 borehole oversight, and has achieved "eye-catching" community-wide sanitation.



Abubakar Ibrahim, the "Handpump Doctor" (Technical Empowerment)

Identifying the Service Gap

Residents of Unguar Arewa 2 suffered from constant shortages and waterborne diseases like cholera because broken boreholes were being abandoned due to a lack of local repair skills.



Professionalizing Local Talent

TCF provided 45-year-old local plumber Abubakar Ibrahim with specialized toolkits and training, transforming him into a certified Local Area Mechanic (LAM).



Innovating for the Local Context

Known as the "Handpump Doctor," Abuhakar invented a locally fabricated "fishing tool" specifically to solve rehabilitation challenges unique to Afridev hand pumps.

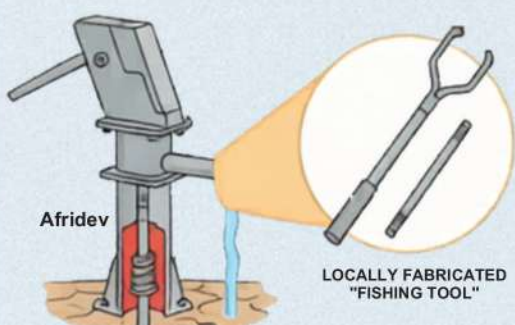

Scaling Impact and Livelihood

Abubakar now earns 50,000 to 70,000 Naira monthly while training local youth, ensuring that clean water access remains permanent and community-managed.





Tulsi Chanrai Foundation (TCF), Nigeria
| Plot 505, Kukwaba, Cadastral Zone, Phase-2, FCT Abuja |
| www.tcfnigeria.org |
| www.tcfeyehospital.org |